

# EPCO Sliding Tracks

# Maverick Hardware

## Sliding Door Tracks and Glides

### Fiber Track and Glides

#### Features

- Hardened fiber tracks and glides are self-lubricating to glide smoothly
- Silent operation
- Durable; no moving parts to wear
- Rust and corrosion proof
- Economical to install
- Doors lift up and out for easy removal



<u>Part #</u>	<u>Length</u>	<u>Description</u>
EP801	6'	Track
EP1801	1 3/8"	Insert

### Sliding Door Track and Glides

Assembly #1 - Extruded aluminum sliding door track and guide system for heavier 1/4" by-passing doors. Bottom track has machined, hardened fiber inserts. Installation screws included.

<u>Part #</u>	<u>Door Type</u>	<u>Length</u>	<u>Material</u>	<u>Finish</u>
EP1A4	Wood/ Glass	4'	Aluminum	Clear Anodized
EP1A6	Wood/ Glass	6'	Aluminum	Clear Anodized

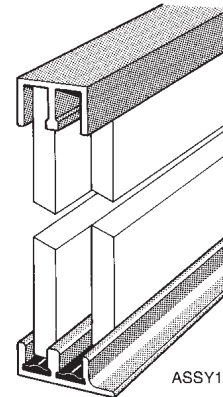

### Sliding Door Track and Glides

Assembly #2 - Extruded aluminum sliding door track and guide system for heavier 3/4" by-passing doors. Bottom track has machined, hardened fiber inserts. Four fiber glides (#1801) recess into bottom of door and glide easily on track. Installation screws included.

<u>Part #</u>	<u>Door Type</u>	<u>Length</u>	<u>Material</u>	<u>Finish</u>
EP2A4	Wood	4'	Aluminum	Clear Anodized
EP2A6	Wood	6'	Aluminum	Clear Anodized

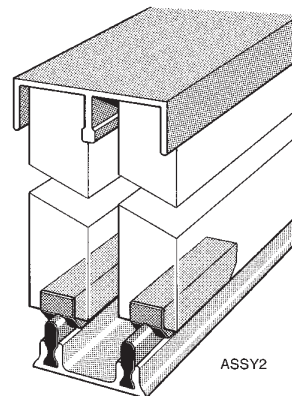

## Sliding Door Tracks and Glides

### Sliding Door Track and Glides

Assembly #8 - Extruded aluminum sliding door track and guide system for heavier 1/4" by-passing doors. Serrated face is designed to provide an attractive finished fascia. Installation screws included.



<u>Part #</u>	<u>Door Type</u>	<u>Length</u>	<u>Material</u>	<u>Finish</u>
EP8A6	Wood/ Glass	6'	Aluminum	Mill Aluminum

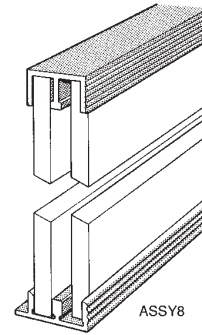

### Sliding Door Track and Glides

Assembly #11 - Extruded aluminum sliding door track and guide system for heavier 3/4" by-passing doors. Serrated face is designed to provide an attractive finished fascia. Four #33 button glides provide a smooth sliding action. Installation screws included.



<u>Part #</u>	<u>Door Type</u>	<u>Length</u>	<u>Material</u>	<u>Finish</u>
EP11A6	Wood	6'	Aluminum	Mill Aluminum

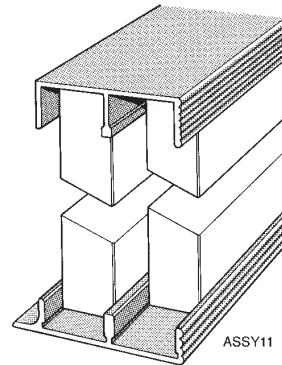

### Sliding Door Track and Glides

Assembly #14 consists of: one 730 upper guide, two 743 shoes, one 723 double track, four 752 rollers, four 771 clip guides, glazing vinyl and mounting screws. Option that can be used with assembly #14 include: 730 side jambs, locks, knobs and pulls. For locks to be effective, side jambs must be used. For glass height, deduct 1 7/32" from opening height.



<u>Part #</u>	<u>Door Type</u>	<u>Length</u>	<u>Material</u>	<u>Finish</u>
EP14A4	Glass	4'	Aluminum	Satin Clear Anodized
EP14A6	Glass	6'	Aluminum	Satin Clear Anodized

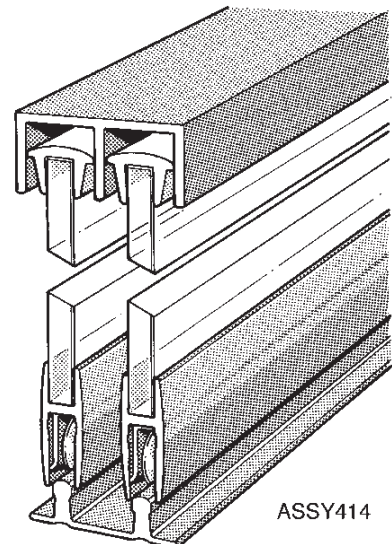

# Maverick Hardware

## Sliding Door Tracks and Glides

Section B-6: EPCO Sliding Tracks

### Sliding Door Track and Glides

Assembly #16 consists of: one 732 upper guide, two 743 shoes, one 723 double track, one 710-A track base, four 752 rollers, four 771 clip guides, glazing vinyl and mounting screws. Option that can be used with assembly #16 include: 730 side jambs, locks, knobs and pulls. For locks to be effective, side jambs must be used. For glass height, deduct 1 7/16" from opening height.



<u>Part #</u>	<u>Door Type</u>	<u>Length</u>	<u>Material</u>	<u>Finish</u>
EP16A4	Glass	4'	Aluminum	Satin Clear Anodized
EP16A6	Glass	6'	Aluminum	Satin Clear Anodized

